	Product name	6.0KW High power charging liquid cooling system	Document number	
	Product model	YG-LCS-O-6.0KW-DC24-A	Edition	A0

6.0KW High power charging liquid cooling system

YG-LCS-O-6.0KW-DC24-A

Technical Specification

Prepared by/Date He Chuanlong_____.

Review/date Zhao Shuang Meng_____.

Ratification/date of approval _____.

Form number	Department	Page number
J3-7.3-48	Vehicle and Energy Information Division Vehicle Product Center	Page 1 of 11

	Product name	6.0KW High power charging liquid cooling system	Document number	
	Product model	YG-LCS-O-6.0KW-DC24-A	Edition	A0

catalogue

1 Product Introduction	4
2 technical parameter	5
3 installation size	6
4 Main components	6
5 Wind direction diagram & layout parameters	7
6 functional characteristics	7
7 Block diagram of electrical control principle	7
8 Communication mode & protocol	8
9 hookup	9
10 Safety precautions	9
11 cleaning and maintenance	10
12 packing inspection	11

Form number	Department	Page number
J3-7.3-48	Vehicle and Energy Information Business Unit Vehicle Product Center	Page 3 of 11

	Product name	6.0KW High power charging liquid cooling system	Document number	
	Product model	YG-LCS-O-6.0KW-DC24-A	Edition	A0

1 Product Introduction

1.1 summary

The HPC Cooling Module Assembly (HPC-CU) is used for Smart High-Power Charging (HPC) technology, with a heat dissipation power of 6.0KW, capable of delivering a charging current exceeding 1500A (at an ambient temperature of 50 °C), while ensuring the safe and stable operation of high-power charging cables. The core technology of this product is to provide cooling fluid at the appropriate temperature and flow rate for high-power charging cables under all operating conditions, ensuring that during the charging process, the temperature rise of the high-power charging cable relative to the ambient temperature does not exceed 50K ($T_{max} = 50K$).

1.2 operational principle

When charging with high-power charging gun wires, it can deliver a charging current of over 1500A. Conventional charging techniques require thick cables or often lead to overheating of the high-power charging gun wires. To facilitate charging operations, the intelligent HPC charging technology employs a liquid-cooling system. In this system, the HPC cooling module assembly uses environmentally friendly cooling media to provide a cold source for the high-power charging gun wires, making maintenance easy. This cooling medium can simultaneously cool both the cable and the DC power terminals of the charging gun. The charging gun terminals have excellent thermal conductivity, so they also serve as heat sinks during charging. By connecting the inlet and outlet pipes of the HPC cooling module assembly to the inlet and outlet pipes of the high-power charging gun wires, a closed loop is formed. Under the drive of a circulation pump, the cooling medium circulates to dissipate heat. The high-power charging gun wires transfer the generated heat to the circulating cooling medium, which then transfers the heat to the heat sink. The heat sink continuously dissipates heat through electronic fans. During this process, the module collects real-time temperatures of the inlet and outlet liquids using sensors and adjusts the pump and fan speeds based on these temperatures, achieving real-time adjustment of

cooling power. This ensures that the high-power charging gun wires operate within an appropriate range, thereby guaranteeing the safe and stable operation of the HPC charging station.

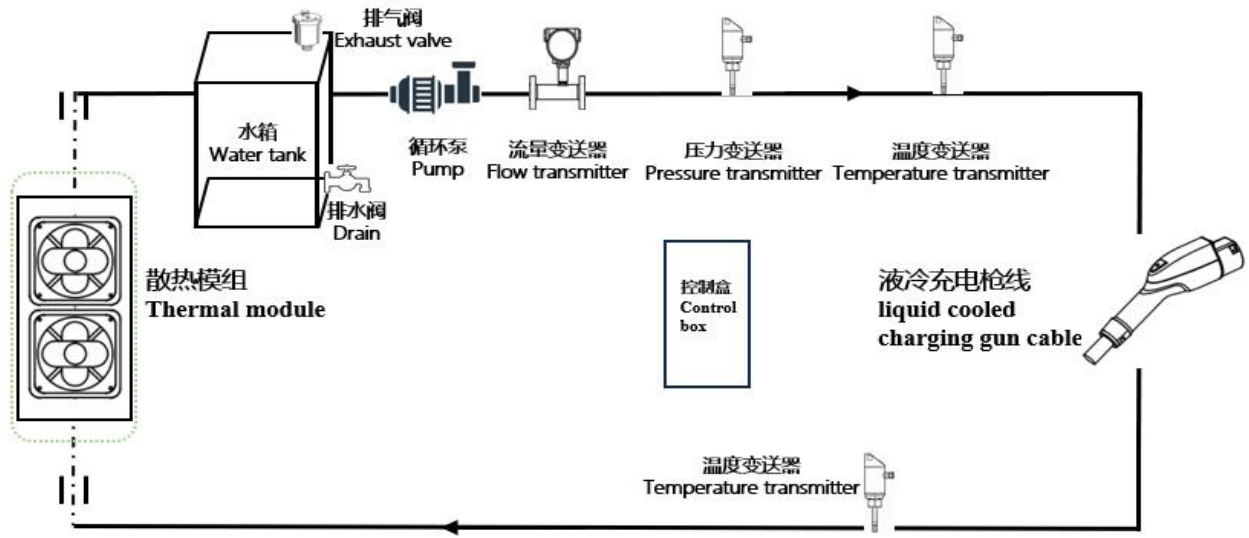



Figure 1 Working principle of high-power charging liquid cooling system

Form number	Department	Page number
J3-7.3-48	Vehicle and Energy Information Division Vehicle Product Center	Page 4 of 11

	Product name	6.0KW High power charging liquid cooling system	Document number	
	Product model	YG-LCS-O-6.0KW-DC24-A	Edi ti on	A0

1.3 External dimensions

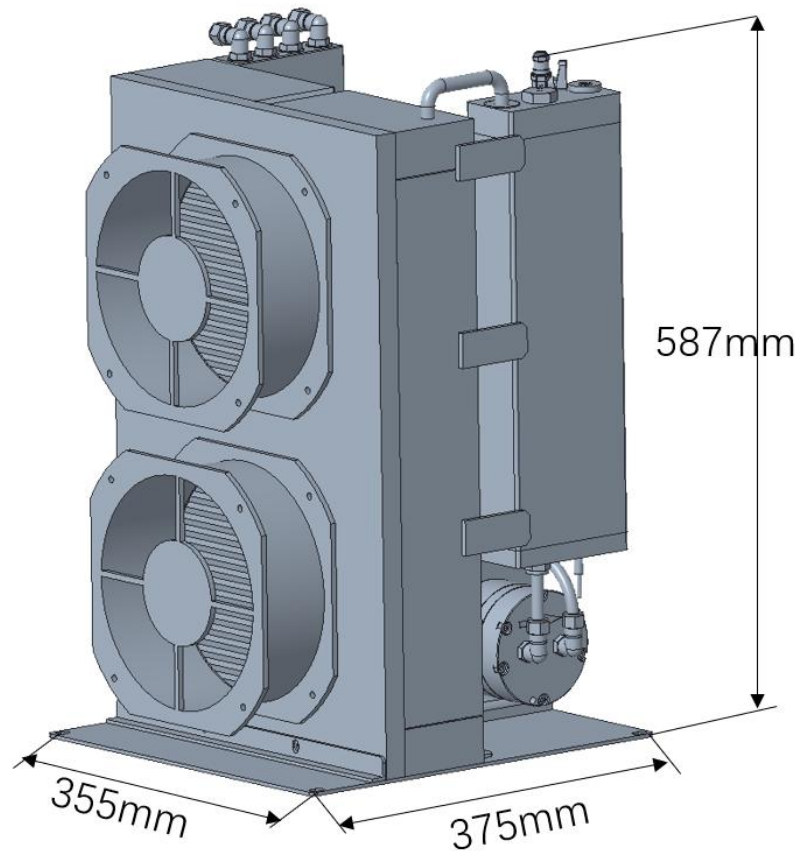

Figure 2 Appearance and size of high-power charging liquid cooling system

2 technical parameter

Table 1 Technical parameters of high power charging liquid cooling system

Size	L355*W375*H587 (mm) with standard mounting base plate	Heat dissipation power	6.0KW@12.0L/min, 1200m ³ /h
Rated voltage	DC24V	Maximum power	≤600W
Cooling medium	① Shell E4, etc. cooling oil ② Antifreeze (water + ethylene glycol)	Medium flow rate	12.0L/min@500Kpa
Maximum pressure	1.0MPa	Working temperature	-40℃~50℃
Weight	25Kg	Expanded flask volume	3L
Noise	≤65dB (A) @1m	Levels of protection	IP55
Control method	Full-automation	Communication mode	RS485
Life span	50000h		

Form number	Department	Page number
J3-7.3-48	Vehicle and Energy Information Business Unit Vehicle Product	Page 5 of 11

	Center	
--	--------	--

	Product name	6.0KW High power charging liquid cooling system	Document number	
	Product model	YG-LCS-O-6.0KW-DC24-A	Edition	A0

3 installation size

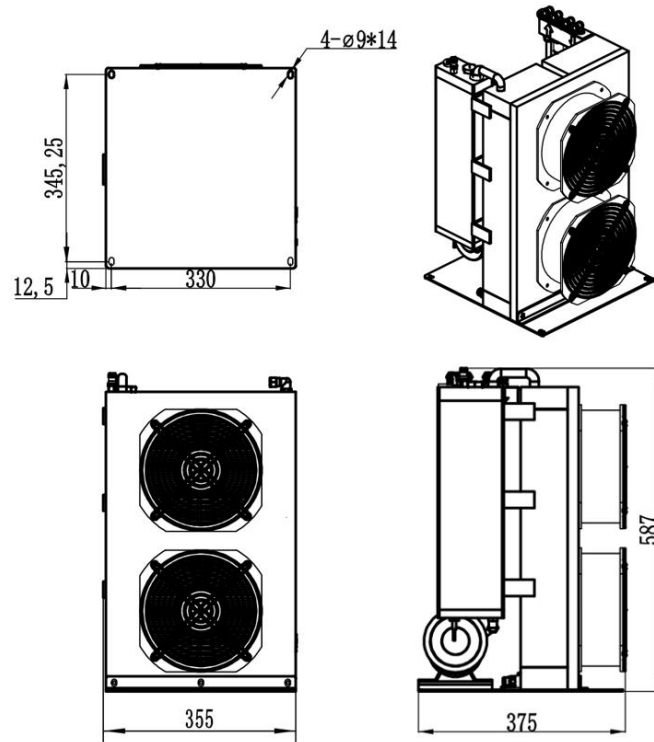

Figure 3 Installation size of high-power charging liquid cooling system

4 Major components

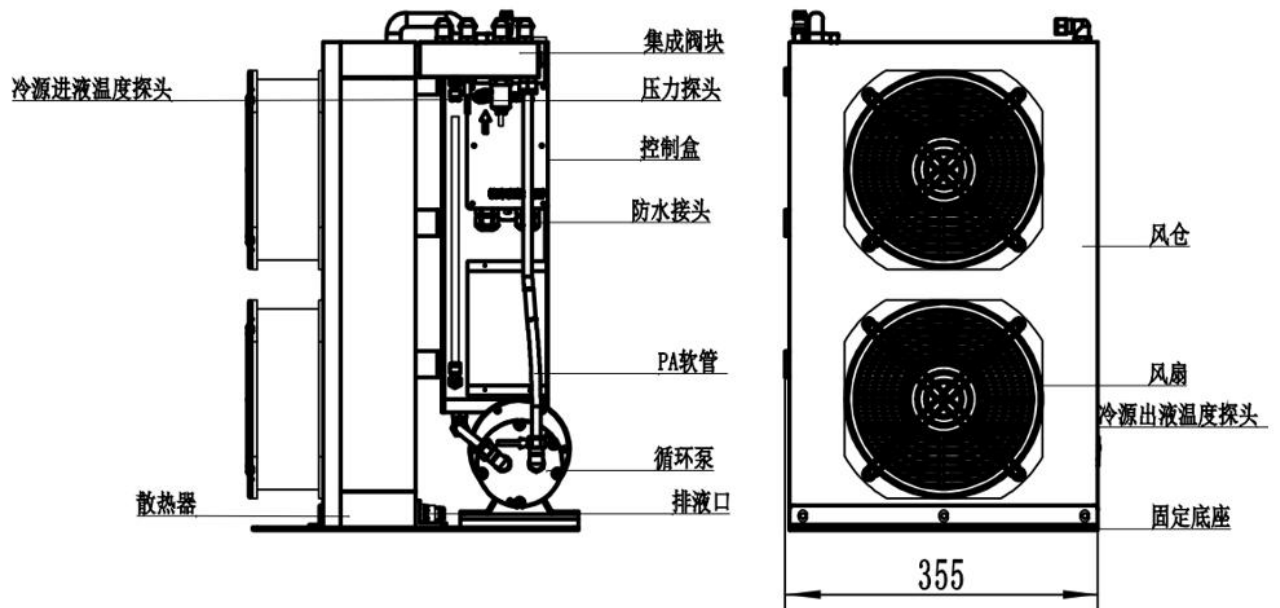



Figure 4 Main components of high power charging liquid cooling system

Form number	Department	Page number
J3-7.3-48	Vehicle and Energy Information Division Vehicle Product Center	Page 6 of 11

	Product name	6.0KW High power charging liquid cooling system	Document number	
	Product model	YG-LCS-O-6.0KW-DC24-A	Edition	A0

5 Wind direction diagram & layout parameters

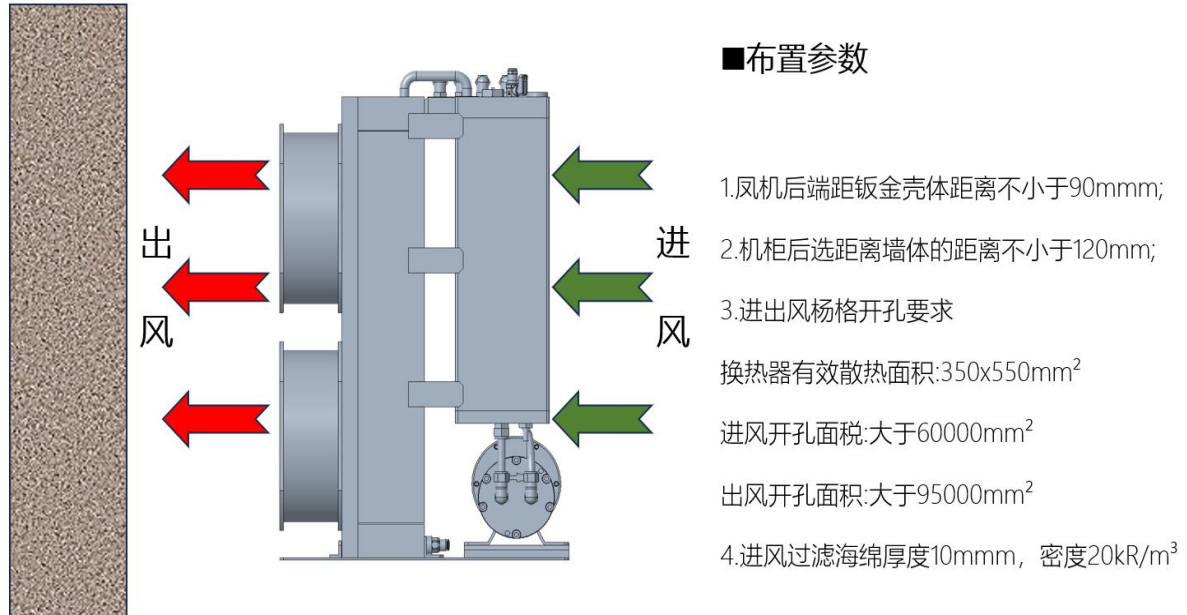

Figure 5 Wind direction diagram & layout parameters

6 functional characteristics

5.1 Vehicle-grade products

Design and development, component selection, experimental verification, manufacturing process and quality control are all developed according to the vehicle specification IATF16949 system.

5.2 IP55 protection

The dust is completely prevented from entering the internal core components, and the product can still operate normally when water is sprayed in all directions of the shell.

5.3 miniaturization

Lightweight, integrated, small size.

5.4 Energy saving

According to the charging condition, the output power of the fan and pump is automatically adjusted to realize energy saving.

5.5 robotization

Automatic control program (standby mode, automatic mode, sleep mode, fault mode, etc.) can extend life and save energy.

7 Block diagram of electrical control principle

Form number	Department	Page number
J3-7.3-48	Vehicle and Energy Information Division Vehicle Product Center	Page 7 of 11

	Product name	6.0KW High power charging liquid cooling system	Document number	
	Product model	YG-LCS-O-6.0KW-DC24-A	Edition	A0

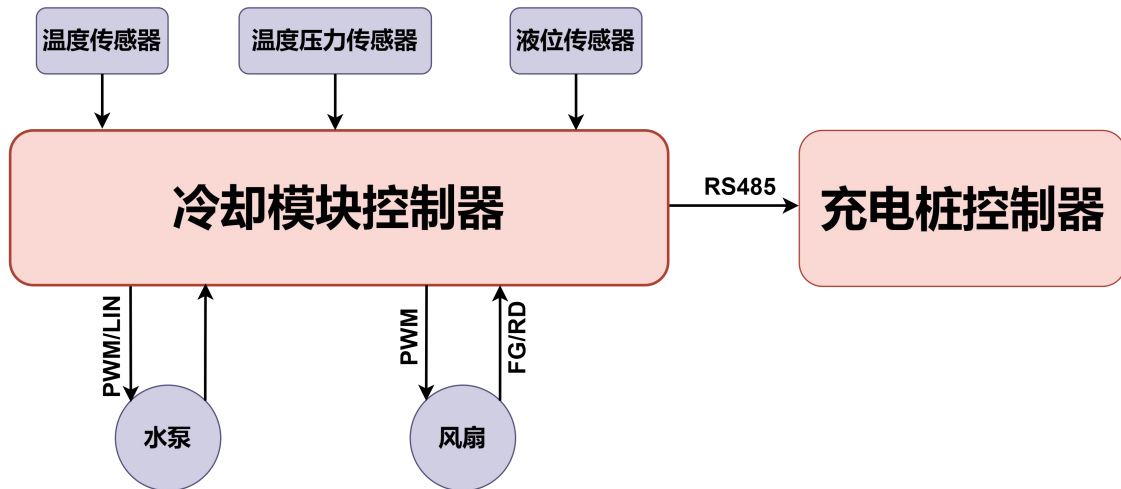

Figure 6 Electrical control principle block diagram of oil cooling system

The functions of the controller include: collecting sensor information, collecting abnormal fault information, communicating with the charging pile terminal, and adjusting the speed of the pump and fan.

1) Collect sensor information

Collect the temperature of the inlet of the radiator, the temperature of the outlet of the radiator and the pressure, and collect the level of the storage tank.

2) Collect abnormal and fault information

Collect information about fan failure, pump failure, temperature sensor failure, temperature and pressure sensor failure, high temperature, high pressure, low pressure, high liquid level, and low liquid level.

3) Communicate with the charging pile

Based on the RS485 communication Modbus RTU standard protocol, in automatic mode: after receiving local or remote start commands, the liquid cooling system automatically starts and monitors the operation of the water cooling device according to set parameters and detects system faults. The liquid cooling control system uploads real-time operational status at the preset upload time and promptly displays any abnormal parameters; when parameters severely exceed limits that could affect the safe operation of the cooled components, the communication will upload warning information. The main pump and fans (sets) are automatically controlled by a microcontroller based on actual working conditio-

ns.

For example, receive "whether charging is in progress", "whether current limiting charging is in progress", and "whether debugging and maintenance is in progress".

4) Control the fan and pump

The controller compares the current temperature collected with the set upper limit value (which needs to be calibrated) (for example, the current inlet oil temperature and the current inlet oil temperature upper limit value), uses the control algorithm to obtain the target speed of the fan and oil pump, and then adjusts the pump speed and fan speed.

8 Communication mode & protocol

Form number	Department	Page number
J3-7.3-48	Vehicle and Energy Information Business Unit Vehicle Product Center	Page 8 of 11

	Product name	6.0KW High power charging liquid cooling system	Document number	
	Product model	YG-LCS-O-6.0KW-DC24-A	Edition	A0

The cooling module is responsible for collection and control, and sends information to the charging pile through the communication module. Communication mode: RS485 serial asynchronous half-duplex, level control.

Communication protocol: Modbus RTU, baud rate 19200

9 hookup

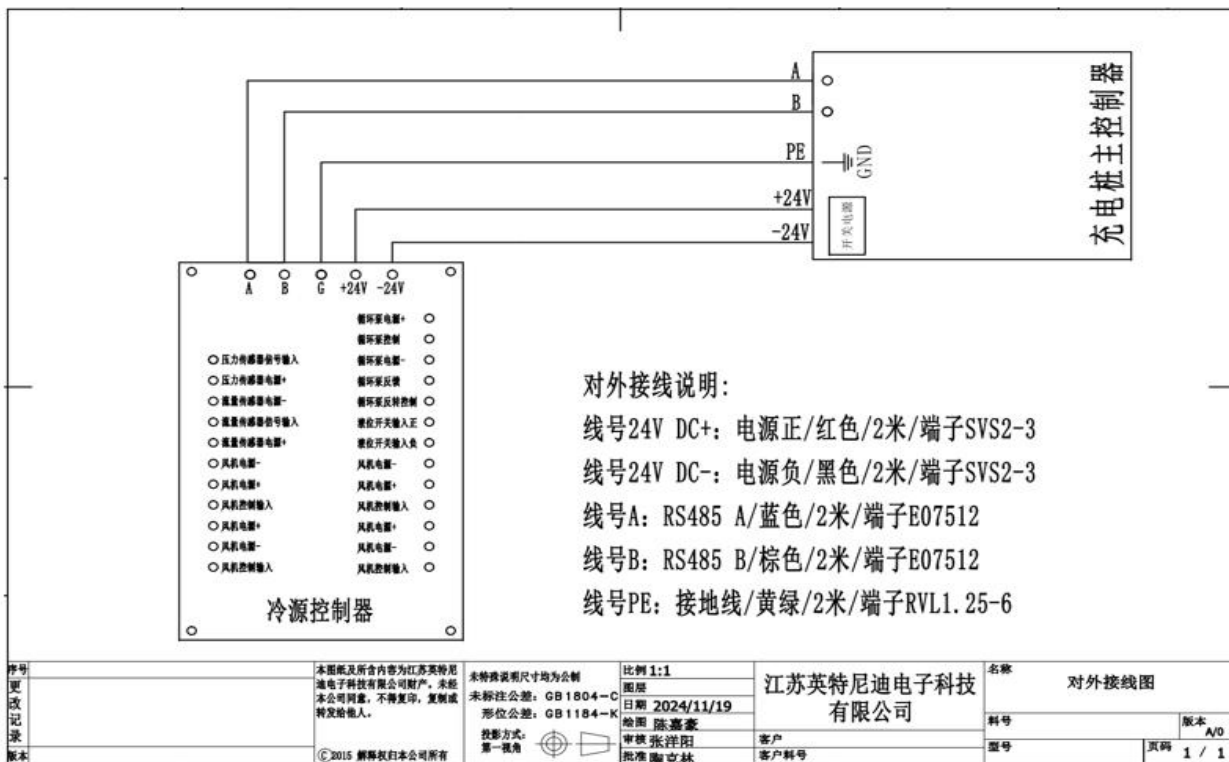

Figure 7 Oil cooling module wiring diagram

* Note: The user only needs to connect the 5 wires between the "terminal port" and the "charging pile" to start the system through RS485, that is, 485-A, 485-B, 24V+, PE, 24V-.

Table 2 Definition of oil cooling equipment wiring

Order number	Name	Conductor cross-sectional area (mm ²)	Terminal model	Remarks
1	PE	1.5	RVL1.25	Landscape (optional)
2	485-A	0.75	E07512	CI
3	485-B	0.75	E07512	CI

4	DC24V+	1.5	SVS2-3	Controller power supply
5	DC24V-	1.5	SVS2-3	Controller power supply

10 Safety precautions

Form number	Department	Page number
J3-7.3-48	Vehicle and Energy Information Division Vehicle Product Center	Page 9 of 11

	Product name	6.0KW High power charging liquid cooling system	Document number	
	Product model	YG-LCS-O-6.0KW-DC24-A	Edition	A0

9.1 This product supports the following cooling media: dimethyl silicone oil, Shell E4 CCF, coolant. However, it does not support the mixing or replacement of the two media. Do not use the above two cooling media without authorization, otherwise it will lead to the degradation or damage of the cooling module performance, as well as the damage of the high-power charging gun line.

9.2 In case of accidental contact with human body, please follow the following procedures or consult a doctor.

Skin contact: Wash with plenty of water.

Eye contact: rinse your eyes thoroughly with water for several minutes. If you wear contact lenses, remove them after rinsing for 1-2 minutes and continue to rinse for several minutes. If you experience any discomfort in your eyes, consult a doctor, preferably an ophthalmologist.

9.3 Fire extinguishing medium:

a) Dimethyl silicone oil: carbon dioxide (CO₂), chemical dry powder.

b) Uncle butyl p-methylphenol (carbon chain C18-50, branched): foam, sprinkling or spraying. Dry chemical fire extinguishing powder, carbon dioxide, sand or soil are only suitable for small-scale fires.

c) Degradable hydrocarbon fluid (Shell E4 coolant) medium: carbon dioxide, fire extinguishing powder or fog spray water. Large fires are extinguished with A-Sol foam or spray water with appropriate surfactant additives.

9.4 The oil pot cover is filled with cooling medium and opened when necessary, and the rest of the cover is kept tight to prevent dust, small particles, water and other substances from entering to avoid blockage or safety accidents.

9.5 Children are forbidden to touch.

9.6 Do not touch the running product with your hands to prevent fan injury.

9.7 Do not touch the radiator during the operation of the product to prevent burns.

9.8 Smoking and fire are prohibited around the product to avoid safety accidents.

11 cleaning and maintenance

10.1 Cleaning can only be done when the product is not powered on.

10.2 Use a dry cloth to clean the electrical parts and other parts.

10.3 Do not use corrosive cleaning agents, water guns, or steam guns for cleaning.

10.4 Most of the parts of the product are thermoplastic plastics. Do not let the product be impacted by external forces to avoid affecting its use.

10.5. The expansion pot level should be checked regularly during the use of the product to avoid damage and safety accidents caused by the failure of the level sensor without alarm. It is recommended that the inspection cycle is once a quarter.

10.6. Regularly check whether there is leakage in each connection part of the product.

Form number	Department	Page number
J3-7.3-48	Vehicle and Energy Information Division Vehicle Product Center	Page 10 of 11

	Product name	6.0KW High power charging liquid cooling system	Document number	
	Product model	YG-LCS-O-6.0KW-DC24-A	Edition	A0

12 packing inspection

11.1 The HPC cooling module assembly is packed in a wooden box. After removing the packing, please check the products and accessories according to the packing list.

11.2 After removing the packaging, make sure that the HPC cooling module assembly is placed vertically and not upside down or sideways.

11.3 If the HPC cooling module assembly is not installed immediately, check and repackage it after completion.

Form number	Department	Page number
J3-7.3-48	Vehicle and Energy Information Business Unit Vehicle Product Center	Page 11 of 11