

SVP300 DC CONTACTOR

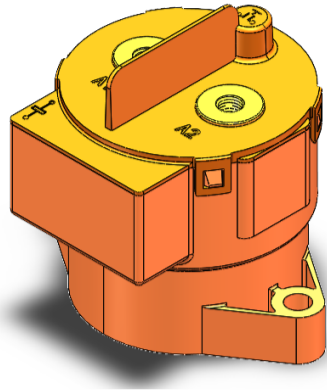

FEATURES:

- With ceramic seal structure, the contact chamber filled with hydrogen mixed reducing gas, combined with magnetic blow-out. Voltage contactor can cut off load voltage of 1000VDC.
- The model with auxiliary contact can monitor the position of the main contact in real time, and is suitable for the charging product field where the main contact is required to be monitored in real time.
- The main / auxiliary contacts in a sealed, hydrogen mixed reduced gas environment are not easily contaminated or oxidized even in the harshest

COIL SPECIFICATION

| NOMINAL VOLTAGE | | MAX.STARTING CURRENT (A) | MAX. IMPACT TIME (m s) | NOMINAL OPERATING CURRENT (A) | PULL-IN VOLTAGE (V) | DROP-OUT VOLTAGE (V) | COIL POWER (W) | MAX. ALLOWABLE VOLTAGE (V) |
|-----------------|------|--------------------------|------------------------|-------------------------------|---------------------|----------------------|----------------------------|----------------------------|
| ITEM | | | | | | | | |
| DC | 9-36 | 3.6A | 120ms | 0.13A@12VDC 0.07A@24VDC | ≤9VDC | ≥3VDC | 43.2W (0.12s) Keep 1.7W | 36VDC |

PART NUMBERING RULE

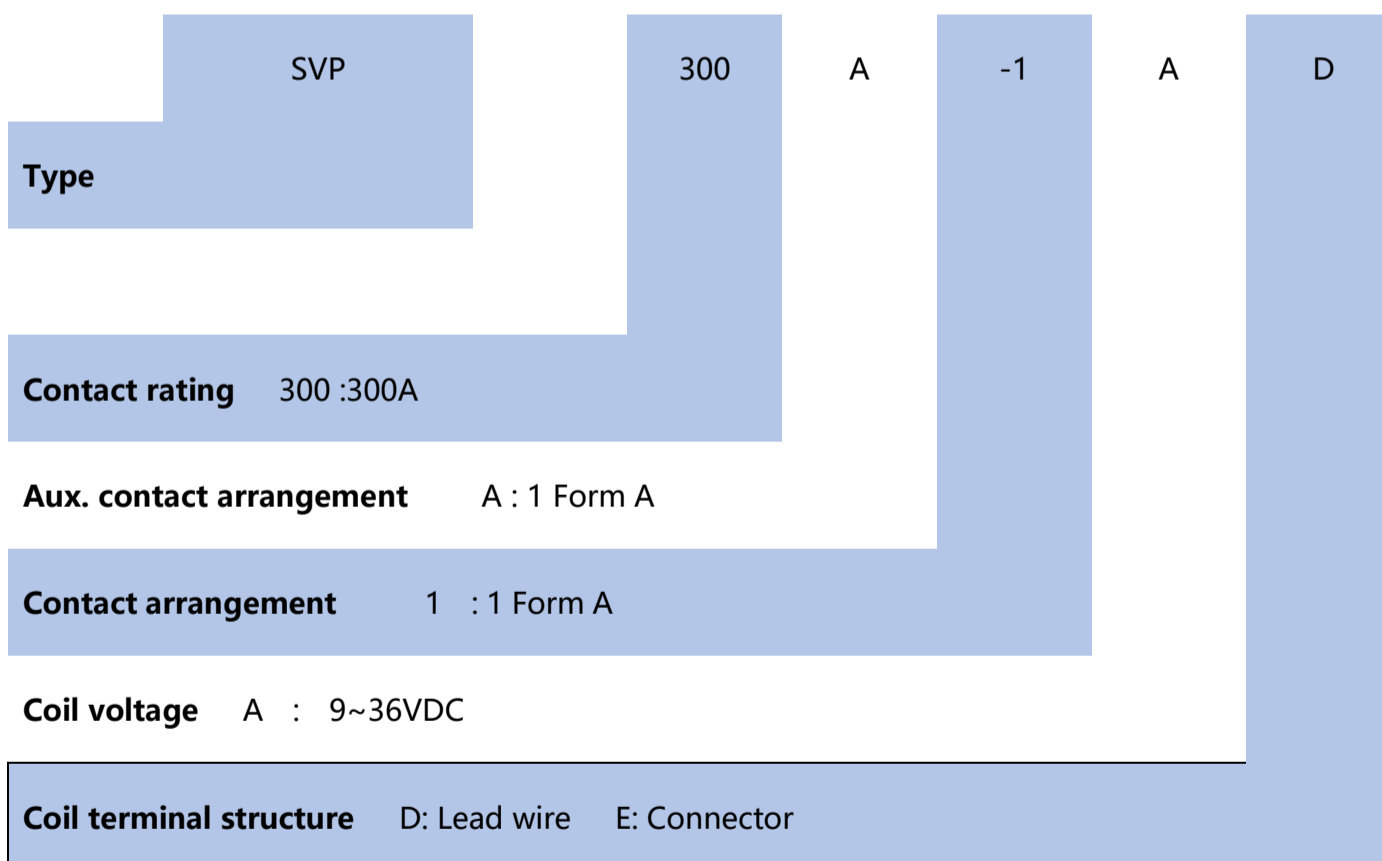

CONTACT RATINGS

| ITEM MODEL | Unipolar resistive load(L/R≤1ms) | |
|--|----------------------------------|-----------------------|
| | SVP300 | |
| Maximum Continuous Current | 300A | |
| Maximum Cut Off | V | 1000 VDC |
| | A | 2500A (280 VDC) 1 Ops |
| Overload cut off | 500A 750VDC 10 Ops | |
| Min. Switching Capacity (Resistive Load) | 1A 12VDC | |
| Short Term Current | 320A 10min, 500A 10s, 2000A 1s | |
| Contact Resistance | ≤0.4mΩ (DC300A) | |
| Contact Material | Alloy Cu | |
| Contact Arrangement | 1A (SPST-NO.) | |
| General Auxiliary Contacts Current Range | 2A 30VDC | |
| General Minimum Current Auxiliary Contacts | 100mA 8VDC | |

INSULATION PERFORMANCE

| | | |
|-------------------------|--------------------------|---------------------|
| Insulation Resistance | | Min.1000MΩ 1000V DC |
| Dielectric Strength | Between Open Contacts | 3500V AC 60 Sec.1mA |
| | Between Contact And Coil | 3500V AC 60 Sec.1mA |
| Operate Time (at 20 °C) | | ≤30ms |
| Release Time (at 20 °C) | | ≤10ms |

MECHANICAL PARAMETERS

| | | | |
|---|--|--|-------------------------|
| Life | Mechanical Life | | 2 x 10 ⁵ Ops |
| | Electrical Life (Resistive Load) (L/R≤1ms) | 450 VDC 300 A | 3,000 Ops |
| | | 800 VDC 300 A | 1,000 Ops |
| | | 1000 VDC 300 A | 500 Ops |
| Shock Resistance | Functional | Min 196 m/s ² [20G] 11ms , (10 μs) | |
| | Destructive | Min 490 m/s ² [50G] 6ms | |
| Vibration Resistance | Functional | 49 m/s ² [5G] 10 to 500Hz , (10 μs) | |
| | Destructive | 49 m/s ² [5G] 10 to 500Hz 4h | |
| Conditions For Operation, Transport And Storage | Ambient Temperature | | -40°C to +85°C |
| | Humidity | | 5% to 85% R.H. |
| Weight | | | ≈380g |

ENGINEERING DATA

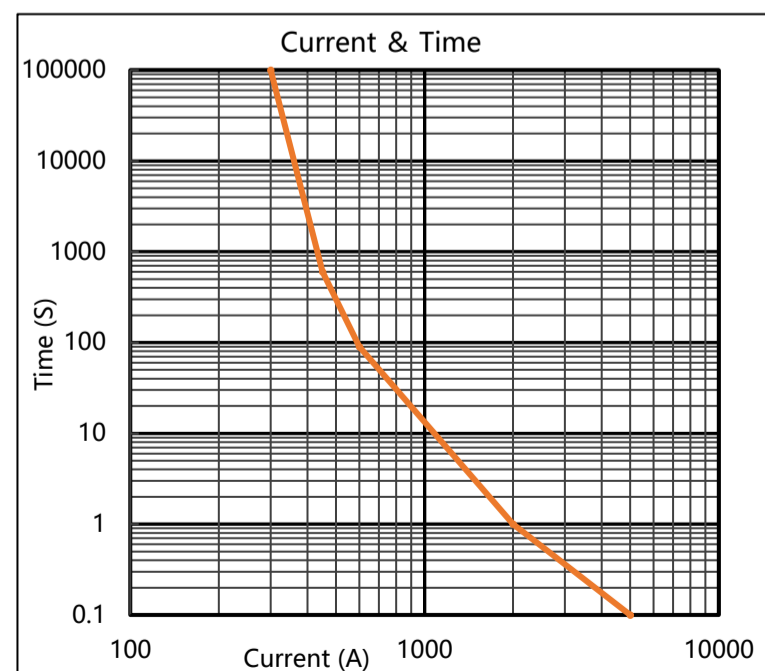
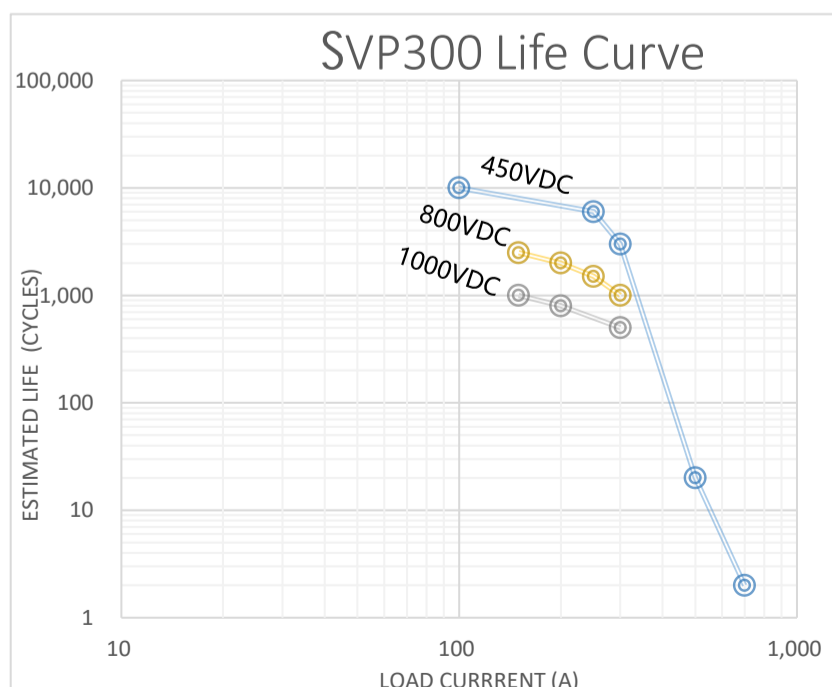

DIMENSIONAL DRAWING

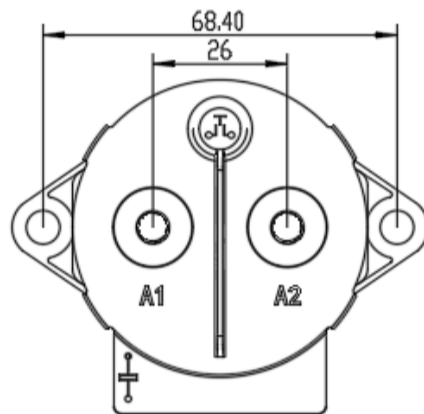
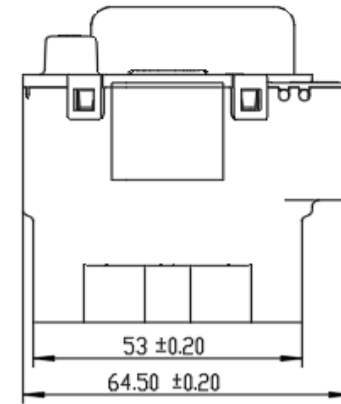
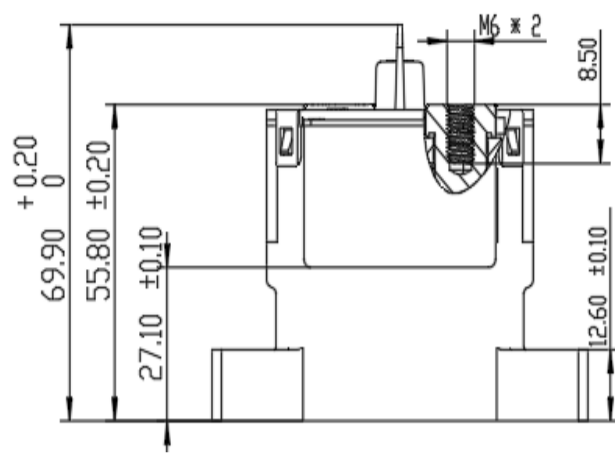

1. Coil wire: UL10267 AWG22, length 320mm±20mm, red: positive, black: negative
2. Auxiliary contact wire: UL10267 AWG22, length 320mm±20mm, black;
3. Main contact non-polarity;

MOUNTING DIMENSIONS

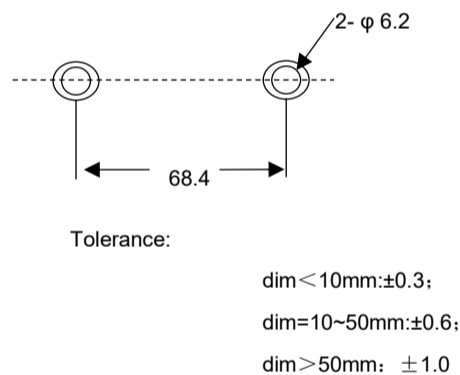

SCHEMATIC

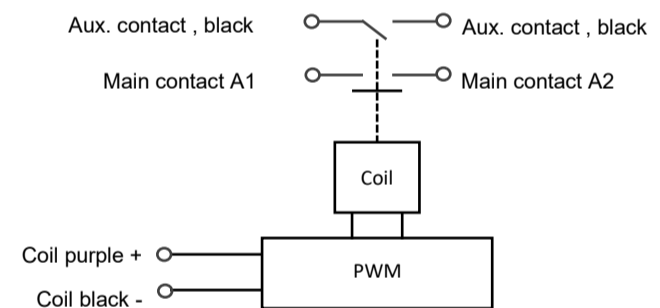

CONTACTOR APPLICATION PRECAUTIONS

SV series high voltage DC contactor with higher arc cooling capacity hydrogen medium, have the ability of DC high voltage cutting and adopt ceramic sealing explosion-proof structure. Contact part have waterproof, anti oxidation and other functions.

It can be widely used in electric vehicles, hybrid vehicles, fuel cell vehicles, construction machinery, photovoltaic power generation, wind power generation, battery charging and discharging system, DC voltage power control and other DC high voltage fields.

Notes:

1. All types of contactor terminals have polarity difference. Please use correctly according to the mark on each surface of the product. When the connection polarity is reversed, the electrical characteristics promised in the specification will not be guaranteed.
2. The rated value of contact parameters are the value of resistive load. Without measures, there may be a decline in electrical life and the occurrence of cut off. If using diodes, it may lead to a decline in cutting performance
3. During the action voltage test of double coil contactor, voltage can not be risen slowly. Please drive the product coil through the fast rising (step type power supply mode), otherwise the contactor will not act.
4. Don't put the contactor in the environment that over normal operating temperature (-40 degrees C to 85 C) for a long time.
5. Please avoid installing near in strong magnetic field (around transformer and magnet) and hot objects.

6. Make sure the main power line is closest to the contactor leading-out terminal, then installed tightly according to the order of the flat washer, spring washer and nut. Incorrect connection order may cause serious overheating, and lead to the insulation layer melting of connecting cable.

7. Screw locking torque of every part should be accordant with following chart in case of breakage.

➤ **Part I Leading-out terminal installation:**

| | | | | |
|----------------|-----------|-------------|-------------|-------------|
| CREWS MODEL | SVC050 | SVC/P150 | SVC300 | SVC600 |
| | SVC100 | SVC/P200 | SVC350 | / |
| | SVC135 | SVC/P250 | SVC400 | / |
| | / | SVC/P300 | SVC500 | / |
| M5 | 6N.m~8N.m | / | / | / |
| M6 | / | 10N.m~12N.m | 10N.m~12N.m | / |
| M8 | / | 10N.m~12N.m | 10N.m~12N.m | / |
| M12 | / | / | / | 10N.m~12N.m |

Remarks: SVC050、SVC100、SVC135 use screws M5x10.

➤ **Part II contactor installation:**

| | | | | |
|----------------|-----------|-------------|-----------|-----------|
| CREWS MODEL | SVC050 | SVC/P150 | SVC300 | SVC600 |
| | SVC100 | SVC/P200 | SVC350 | / |
| | SVC135 | SVC/P250 | SVC400 | / |
| | / | SVC/P300 | SVC500 | / |
| M4 | 3N.m~4N.m | / | / | / |
| M5 | / | 6N.m~8N.m | 6N.m~8N.m | 6N.m~8N.m |
| M6 | / | 10N.m~12N.m | / | / |

Remarks:

a. Screw strength must be in compliance with the requirements of grade 8.8 or above (GB/T70.1)

b. The effective locking thread length must be greater than 5mm.

8.Packing specification

| | | | | |
|------------------------|----------------|----------------|----------------|----------------|
| Each box MODEL | SVC050 | SVC/P150 | SVC300 | SVC600 |
| | SVC100 | SVC/P200 | SVC350 | / |
| | SVC135 | SVC/P250 | SVC400 | / |
| | / | SVC/P300 | SVC500 | / |
| Specifications (D*W*H) | 412*407*146 mm | 382*302*196 mm | 382*302*196 mm | 382*302*196 mm |
| Number | 60 PCS | 24 PCS | 24 PCS | 12PCS |
| Net weight | 10.8 kg | 9.12 kg | 13.2 kg | 10.8 kg |
| Monomer | 0.18 kg | 0.38 kg | 0.55 kg | 0.90 kg |

Remarks: there is a shockproof bubble bag in the packing box, and there is shockproof foam inside the box.

9.Please avoid adhering grease and other foreign material on the leading-out terminal;

Please use the following specifications of the connection wire, otherwise it may cause abnormal heat of the terminal part.

| MODEL | SVC050 | SVC100 | SVC135 | SVC/P150 | SVC/P200 | SVC/P250 | SVC/P300 | SVC350 | SVC500 |
|-------------------------|--------|--------|--------|----------|----------|----------|----------|--------|--------|
| | | | | | | | | SVC400 | SVC600 |
| Area (mm ²) | 16 | 35 | 50 | 70 | 95 | 150 | 185 | 240 | 185*2 |

10. In the case of accidental fall of the contactor, see intended not to use.

11. Attentions and product technical data should be updated termly, and copyright by Ebusbar all.