

# SVL150

# DC CONTACTOR



## FEATURE

- The ceramic structure, micro electric vehicles (car) at low speed o product, The relay can cut off the load voltage of 450 VDC.
- The load and coil driver non-polarity requirements.
- Current-carrying 150 A for a long time at 85 °C.

## COIL SPECIFICATION

ITEM		COIL RESISTANCE (Ω)	NOMINAL OPERATING CURRENT (A)	PULL-IN VOLTAGE (V)	DROP-OUT VOLTAGE (V)	COIL POWER (W)	MAX. ALLOWABLE VOLTAGE (V)
DC	12	32Ω	0.375A	≤9VDC	≥1VDC	4.5W	16VDC
	24	128Ω	0.128A	≤18VDC	≥2VDC	4.5W	32VDC

## PART NUMBERING RULE

SVL	150	-	1	12	D	H
Series	Rated Current	Auxiliary contact	Contact Type	Coil Voltage	Coil lead	Coil wires isolation
SVL=Low voltage type	150: 150 A	Null:No auxiliary contact	1: 1a Normally Open	12: 12 VDC 24: 24 VDC	D=Direct wire without connection plug E=Direct wire with connector plug	blanc - 300V H - 3000V

## CONTACT RATINGS

ITEM	MODEL	Unipolar resistive load(L/R≤1ms)	
		SVL150 (Authentication Certificate CE/CCC)	
Maximum Continuous Current		150A	
Maximum Cut Off	V	450 VDC	
	A	1500A (200 VDC) 1 Ops	
Overload cut off		300A 450VDC 10 Ops	
Reverse cut off		1A 12VDC	
Min. Switching Capacity(Resistive Load)		200A 20min, 400A 30s, 1000A 0.6s	
Short Term Current		≤1.5mΩ (DC 150A)	
Contact Resistance		Alloy Cu	
Contact Material		1A (SPST-NO.)	
Contact Arrangement		150A	

## INSULATION PERFORMANCE

Insulation Resistance		Min.1000MΩ 500V DC
Dielectric Strength	Between Open Contacts	2500V AC 60 Sec.1mA
	Between Contact And Coil	2500V AC 60 Sec.1mA
Operate Time(at 20 ℃)		≤30ms
Release Time(at 20 ℃)		≤10ms

## MECHANICAL PARAMETERS

Life	Mechanical Life		2x10 <sup>5</sup> Ops
	Electrical Life (Resistive Load) (L/R≤1ms)	48 VDC 150 A	15,000 Ops
		72 VDC 150 A	10,000 Ops
		200 VDC 150 A	5,000 Ops
		450 VDC 150 A	800 Ops
Shock Resistance	Functional		Min 196 m/s <sup>2</sup> [20G] 11ms , (10 μs)
	Destructive		Min 490 m/s <sup>2</sup> [50G] 6ms
Vibration Resistance	Functional		49 m/s <sup>2</sup> [5G] 10 to 500Hz , (10 μs)
	Destructive		49 m/s <sup>2</sup> [5G] 10 to 500Hz 4h
Conditions For Operation, Transport And Storage	Ambient Temperature		-40℃ to +85℃
	Humidity		5% to 85% R.H.
Weight			300g

# ENGINEERING DATA

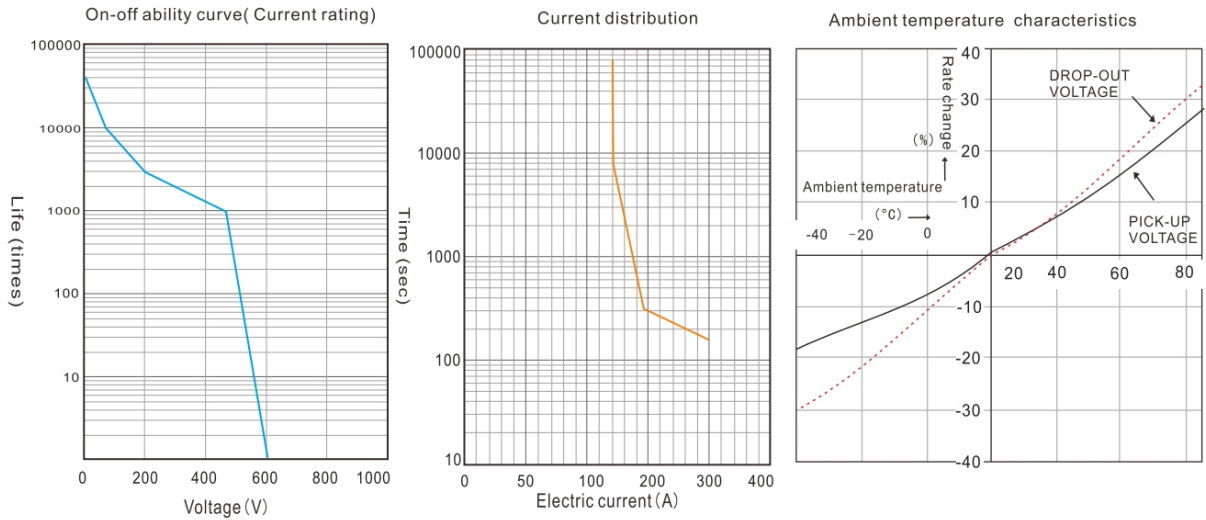

# DIMENSIONAL DRAWING

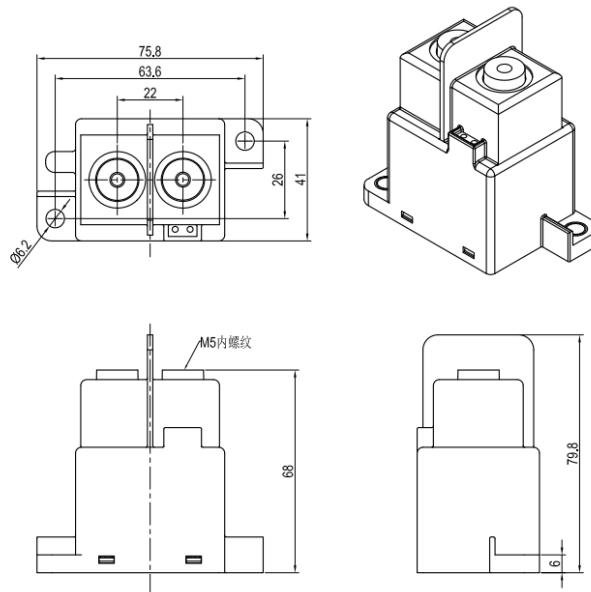

# MOUNTING DIMENSIONS

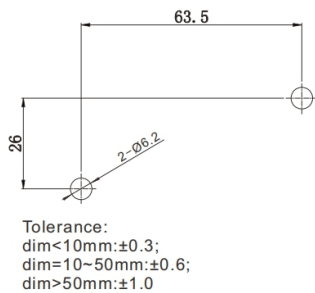

# SCHEMATIC

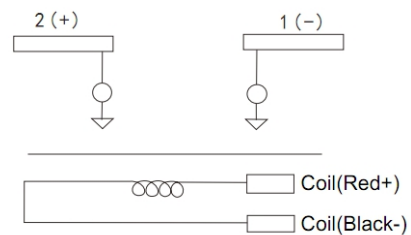

Coil extraction mode 300V wire: UL3266、20AWG、320±20mm (Connectors can be configured by the customer)  
 Coil extraction mode 3000V wire: UL10267、22AWG、320±20mm (Connectors can be configured by the customer)

## CONTACTOR APPLICATION PRECAUTIONS

EV series high voltage DC contactor with higher arc cooling capacity hydrogen medium, have the ability of DC high voltage cutting and adopt ceramic sealing explosion-proof structure. Contact part have waterproof, anti oxidation and other functions.

It can be widely used in electric vehicles, hybrid vehicles, fuel cell vehicles, construction machinery, photovoltaic power generation, wind power generation, battery charging and discharging system, DC voltage power control and other DC high voltage fields.

### Notes:

- 1.All types of contactor terminals have polarity difference. Please use correctly according to the mark on each surface of the product. When the connection polarity is reversed, the electrical characteristics promised in the specification will not be guaranteed.
- 2.The rated value of contact parameters are the value of resistive load. Without measures, there may be a decline in electrical life and the occurrence of cut off. If using diodes, it may lead to a decline in cutting performance
- 3.During the action voltage test of double coil contactor, voltage can not be risen slowly. Please drive the product coil through the fast rising (step type power supply mode) , otherwise the contactor will not act.
- 4.Don't put the contactor in the environment that over normal operating temperature (-40 degrees C to 85 C) for a long time.
- 5.Please avoid installing near in strong magnetic field (around transformer and magnet ) and hot objects.
- 6.Make sure the main power line is closest to the contactor leading-out terminal, then installed tightly according to the order of the flat washer, spring washer and nut. Incorrect connection order may cause serious overheating, and lead to the insulation layer melting of connecting cable .
- 7.Screw locking torque of every part should be accordant with following chart in case of breakage.

### ➤ Part I Leading-out terminal installation:

MODEL	SVL100	SVL150	SVL200	SVL250
CREWS	/	/	/	/
M4	/	/	/	/
M5	6N.m~8N.m	6N.m~8N.m	6N.m~8N.m	6N.m~8N.m
M6	/	/	/	/

Remarks: SVL100、SVL150、SVL200、SVL250、 use screws .

➤ Part II contactor installation:

MODEL	SVL100	SVL150	SVL200	SVL250
CREWS	/	/	/	/
M5	6N.m~8N.m	6N.m~8N.m	6N.m~8N.m	6N.m~8N.m
M6	10N.m~12N.m	10N.m~12N.m	10N.m~12N.m	10N.m~12N.m

Remarks: a. Screw strength must be in compliance with the requirements of grade 8.8 or above (GB/T70.1) ;

b. The effective locking thread length must be greater than 5mm.

8.Packing specification

MODEL	SVL100	SVL150	SVL200	SVL250
Each box	/	/	/	/
Specifications (D*W*H)	382*302*196 mm	382*302*196 mm	382*302*196 mm	382*302*196 mm
Number	24 PCS	24 PCS	24 PCS	24 PCS
Net weight	7.2 kg	7.2 kg	7.2 kg	7.2 kg
Monomer	0.3 kg	0.3 kg	0.3 kg	0.3kg

Remarks: there is a shockproof bubble bag in the packing box, and there is shockproof foam inside the box.

9.Please avoid adhering grease and other foreign material on the leading-out terminal; Please use the following specifications of the connection wire, otherwise it may cause abnormal heat of the terminal part.

MODEL	SVL100	SVL150	SVL200	SVL250
Area (mm <sup>2</sup> )	35	70	95	150

10.In the case of accidental fall of the contactor, see intended not to use.

11.Attentions and product technical data should be updated termly, and copyright by Ebusbar all.