

SVC300

DC CONTACTOR



FEATURE

- With ceramic seal structure, the contact chamber filled with hydrogen mixed educing gas, combined with magnetic blow-out. Voltage contactor can cut off load voltage of 1000VDC.
- The model with auxiliary contact can monitor the position of the main contact in real time, and is suitable for the charging product field where the main contact is required to be monitored in real time.
- The main / auxiliary contacts in a sealed, hydrogen mixed reduced gas environment are not easily contaminated or oxidized even in the harshest environments.

COIL SPECIFICATION

NOMINAL VOLTAGE		MAX. STARTING CURRENT (A)	MAX. IMPACT TIME (ms)	NOMINAL OPERATING CURRENT (A)	PULL-IN VOLTAGE (V)	DROP-OUT VOLTAGE (V)	COIL POWER (W)	MAX. ALLOWABLE VOLTAGE (V)
ITEM								
DC	9-36	3.6A	120ms	0.13A@12VDC 0.07A@24VDC	≤9VDC	≥3VDC	43.2W (0.12s) Keep 1.7W	36VDC

PART NUMBERING RULE

<u>SVC</u>	<u>300</u>	<u>A</u>	-	<u>1</u>	<u>A</u>	<u>D</u>	<u>P</u>	<u>W</u>	<u>H</u>
Series	Rated Current	Auxiliary contact	Contact Type	Coil Voltage	Coil lead	ECO Mode	Contact Polarity	Coil wires Isolation	
SVC=Circular type	300: 300 A	Null:no auxiliary contact	1: 1a Normally Open	A: 9-36 VDC	D=direct wire without connection plug	Blanky: Internal PWB	Null:With polarity	blanc - 300V	
		A:With auxiliary contact			E=direct wire with connector plug	P= external PWB	W:No polarity		H - 3000V

CONTACT RATINGS

ITEM MODEL	Unipolar resistive load(L/R≤1ms)	
	SVC300 (Authentication Certificate CE/CCC)	
Maximum Continuous Current	300A	
Maximum Cut Off	V	1000 VDC
	A	2500A (300 VDC) 1 Ops
Overload cut off	500A 750VDC 10 Ops	
Reverse cut off	-300A 200VDC 1000 Ops	
Min. Switching Capacity(Resistive Load)	1A 12VDC	
Short Term Current	320A 10min, 500A 10s, 2000A 1s	
Contact Resistance	≤0.4mΩ (DC300A)	
Contact Material	Alloy Cu	
Contact Arrangement	1A (SPST-NO.)	
General Auxiliary Contacts Current Range	2A 30VDC / 3A 125VAC	
General Minimum Current Auxiliary Contacts	100mA 8VDC	

INSULATION PERFORMANCE

Insulation Resistance		Min.1000MΩ 1000V DC
Dielectric Strength	Between Open Contacts	2500V AC 60 Sec.1mA
	Between Contact And Coil	2500V AC 60 Sec.1mA
Operate Time(at 20 °C)		≤30ms
Release Time(at 20 °C)		≤10ms

MECHANICAL PARAMETERS

Life	Mechanical Life		2x10 ⁵ Ops
	Electrical Life (Resistive Load) (L/R≤1ms)	450 VDC 300 A	3,000 Ops
		750 VDC 300 A	1,000 Ops
		1000 VDC 150 A	1,000 Ops
Shock Resistance	Functional	Min 196 m/s ² [20G] 11ms , (10 μs)	
	Destructive	Min 490 m/s ² [50G] 6ms	
Vibration Resistance	Functional	49 m/s ² [5G] 10 to 500Hz , (10 μs)	
	Destructive	49 m/s ² [5G] 10 to 500Hz 4h	
Conditions For Operation, Transport And Storage	Ambient Temperature		-40°C to +85°C
	Humidity		5% to 85% R.H.
Weight			380g

ENGINEERING DATA

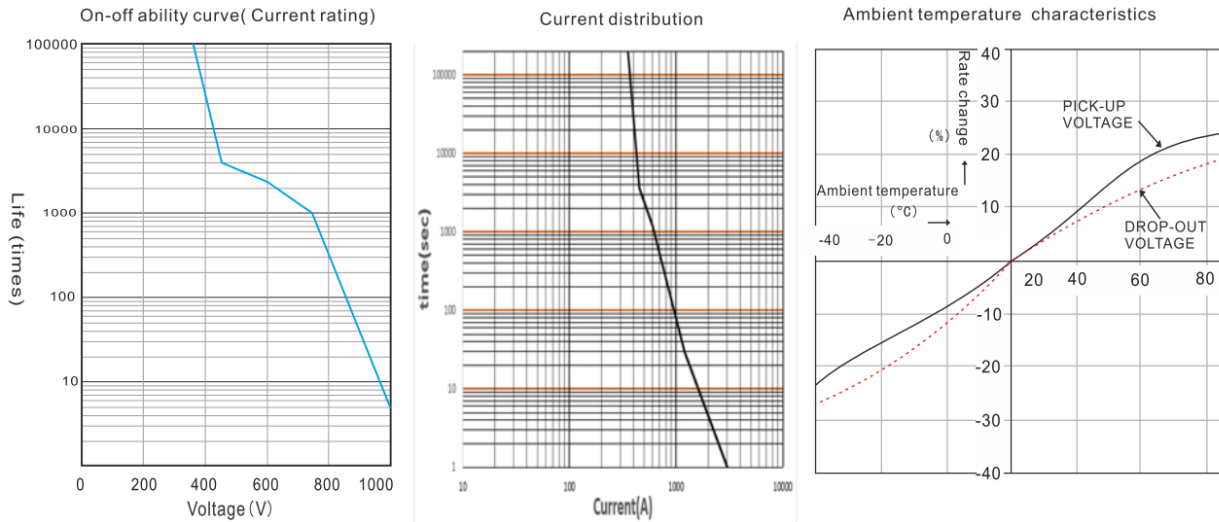

DIMENSIONAL DRAWING

SVC 300 X - X X X _ X

SVC 300 X - X X X P X

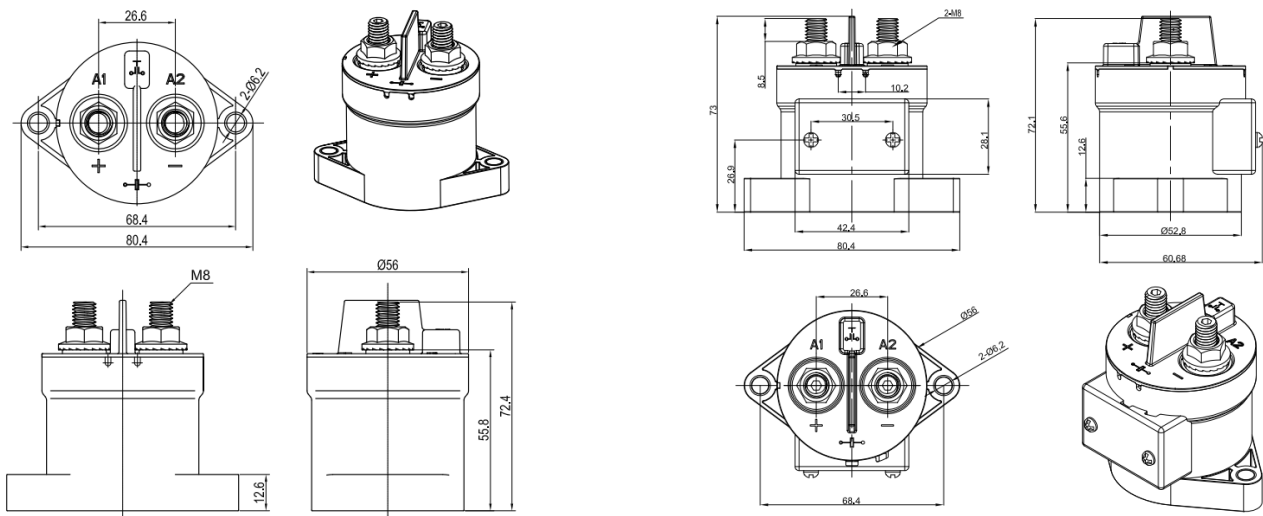

MOUNTING DIMENSIONS

SCHEMATIC

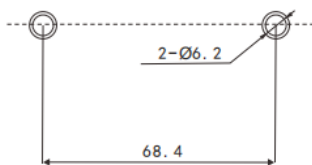

Tolerance:
 dim<10mm:±0.3;
 dim=10~50mm:±0.6;
 dim>50mm:±1.0

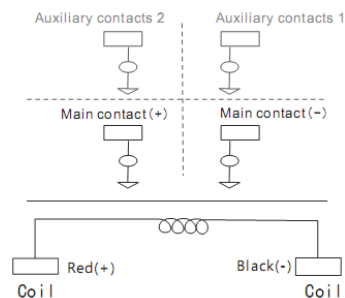

Coil extraction mode 300V wire: UL3266、20AWG、320±20mm (Connectors can be configured by the customer)
 Coil extraction mode 3000V wire: UL10267、22AWG、320±20mm (Connectors can be configured by the customer)

CONTACTOR APPLICATION PRECAUTIONS

SV series high voltage DC contactor with higher arc cooling capacity hydrogen medium, have the ability of DC high voltage cutting and adopt ceramic sealing explosion-proof structure. Contact part have waterproof, anti oxidation and other functions.

It can be widely used in electric vehicles, hybrid vehicles, fuel cell vehicles, construction machinery, photovoltaic power generation, wind power generation, battery charging and discharging system, DC voltage power control and other DC high voltage fields.

Notes:

- 1.All types of contactor terminals have polarity difference. Please use correctly according to the mark on each surface of the product. When the connection polarity is reversed, the electrical characteristics promised in the specification will not be guaranteed.
- 2.The rated value of contact parameters are the value of resistive load. Without measures, there may be a decline in electrical life and the occurrence of cut off. If using diodes, it may lead to a decline in cutting performance
- 3.During the action voltage test of double coil contactor, voltage can not be risen slowly. Please drive the product coil through the fast rising (step type power supply mode) , otherwise the contactor will not act.
- 4.Don't put the contactor in the environment that over normal operating temperature (-40 degrees C to 85 C) for a long time.
- 5.Please avoid installing near in strong magnetic field (around transformer and magnet) and hot objects.
- 6.Make sure the main power line is closest to the contactor leading-out terminal, then installed tightly according to the order of the flat washer, spring washer and nut. Incorrect connection order may cause serious overheating, and lead to the insulation layer melting of connecting cable .
- 7.Screw locking torque of every part should be accordant with following chart in case of breakage.

➤ Part I Leading-out terminal installation:

CREWS MODEL	SVC050	SVC150	SVC300	SVC600
	SVC100	SVC200	SVC350	/
	SVC135	SVC250	SVC400	/
	/	SVC300	SVC500	/
M5	6N.m~8N.m	/	/	/
M6	/	10N.m~12N.m	10N.m~12N.m	/
M8	/	10N.m~12N.m	10N.m~12N.m	/
M12	/	/	/	10N.m~12N.m

Remarks: SVC050、SVC100、SVC135 use screws M5x10.

➤ Part II contactor installation:

CREWS MODEL	SVC050	SVC150	SVC300	SVC600
	SVC100	SVC200	SVC350	/
	SVC135	SVC250	SVC400	/
	/	SVC300	SVC500	/
M4	3N.m~4N.m	/	/	/
M5	/	6N.m~8N.m	6N.m~8N.m	6N.m~8N.m
M6	/	10N.m~12N.m	/	/

Remarks: a. Screw strength must be in compliance with the requirements of grade 8.8 or above (GB/T70.1) ;

b. The effective locking thread length must be greater than 5mm.

8.Packing specification

Each box MODEL	SVC050	SVC150	SVC300	SVC600
	SVC100	SVC200	SVC350	/
	SVC135	SVC250	SVC400	/
	/	SVC300	SVC500	/
Specifications (D*W*H)	412*407*146 mm	382*302*196 mm	382*302*196 mm	382*302*196 mm
Number	60 PCS	24 PCS	24 PCS	12PCS
Net weight	10.8 kg	9.12 kg	13.2 kg	10.8 kg
Monomer	0.18 kg	0.38 kg	0.55 kg	0.90 kg

Remarks: there is a shockproof bubble bag in the packing box, and there is shockproof foam inside the box.

9.Please avoid adhering grease and other foreign material on the leading-out terminal; Please use the following specifications of the connection wire, otherwise it may cause abnormal heat of the terminal part.

MODEL	SVC050	SVC100	SVC135	SVC150	SVC200	SVC250	SVC300	SVC350	SVC500
								SVC400	SVC600
Area (mm ²)	16	35	50	70	95	150	185	240	185*2

10.In the case of accidental fall of the contactor, see intended not to use.

11.Attentions and product technical data should be updated termly, and copyright by Ebusbar all.